

## Compressor Refrigerator

## Model YCD-50 DC

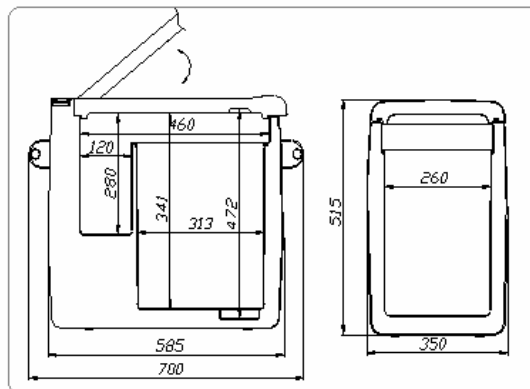

### Specifications :

<b>Gross Capacity:</b>	50 litres
<b>Voltage:</b>	12/24 volts DC
<b>Power</b>	45 watts <b>Average consumption</b>
<b>Average running time:</b>	15% at 20°C ambient temp., 19% at 32°C ambient temp., both at 5°C interior temp.
<b>Power consumption:</b>	0.25KWh/24h
<b>Temperature range:</b>	<b>+10°C to -18°C</b> , adjustable via electronic thermostat with LED indicator
<b>Insulation:</b>	CFC-free polyurethane foam
<b>System:</b>	( <b>Secop</b> ) <b>Danfoss BD35F compressor</b> with integrated control electronics, low voltage protection adjustable for consumer and starter battery via slide switch( High, Med & Low ,3 level battery protection), electronic fuse/automatic reverse pole protection, dynamically ventilated wire tube condenser, aluminium tube-on-sheet evaporator
<b>Material:</b>	Cabinet : PP , Lid : ABS, Inner Liner : Painted Aluminium
<b>Colour:</b>	Body: pale grey/dark grey, lid: dark grey
<b>Weight:</b>	19.3 kg
<b>Product Dimension:</b>	585 x 350 x 515 mm ( L x W x H)
<b>Scope</b>	DC connection cable, detachable carrying handles etc.
<b>Test marks:</b>	CE certified

A-1, Kumar Classics, Aundh, Pune - 411 007, Tel.: (020) 25881704, Fax: (020) 2588 0851  
E-mail: [info@tropicoolindia.com](mailto:info@tropicoolindia.com)

Website: [www.tropicoolindia.com](http://www.tropicoolindia.com) **TROPICool® Car Gadgets Pvt. Ltd.**

**Luxury & Safety On The Wheels ... For The People On The Move**